



US 20040114770A1

(19) **United States**

(12) **Patent Application Publication** (10) **Pub. No.: US 2004/0114770 A1**  
**Pompei** (43) **Pub. Date: Jun. 17, 2004**

(54) **DIRECTED ACOUSTIC SOUND SYSTEM**

**Publication Classification**

(76) Inventor: **Frank Joseph Pompei**, Wayland, MA (US)

(51) **Int. Cl.**<sup>7</sup> ..... **H04B 3/00**  
(52) **U.S. Cl.** ..... **381/77**

Correspondence Address:  
**WEINGARTEN, SCHURGIN, GAGNEBIN & LEBOVICI LLP**  
**TEN POST OFFICE SQUARE**  
**BOSTON, MA 02109 (US)**

(57) **ABSTRACT**

An acoustic sound system usable in electronic entertainment systems that generates highly directional sound. The directed acoustic sound system includes a parametric audio sound system having a modulator for modulating an ultrasonic carrier signal with a processed audio signal, a driver amplifier for amplifying the modulated signal, and a parametric loudspeaker for projecting the modulated and amplified signal through the air for subsequent regeneration of the audio signal along a pre-selected path. The acoustic sound system allows a user to select the parametric loudspeaker, a connectable non-directional loudspeaker, or both loudspeakers for producing audible sound. The acoustic sound system may be employed in the home, in the workplace, or in any other environment where audio leakage is undesirable.

(21) Appl. No.: **10/697,208**

(22) Filed: **Oct. 30, 2003**

**Related U.S. Application Data**

(60) Provisional application No. 60/422,582, filed on Oct. 30, 2002.

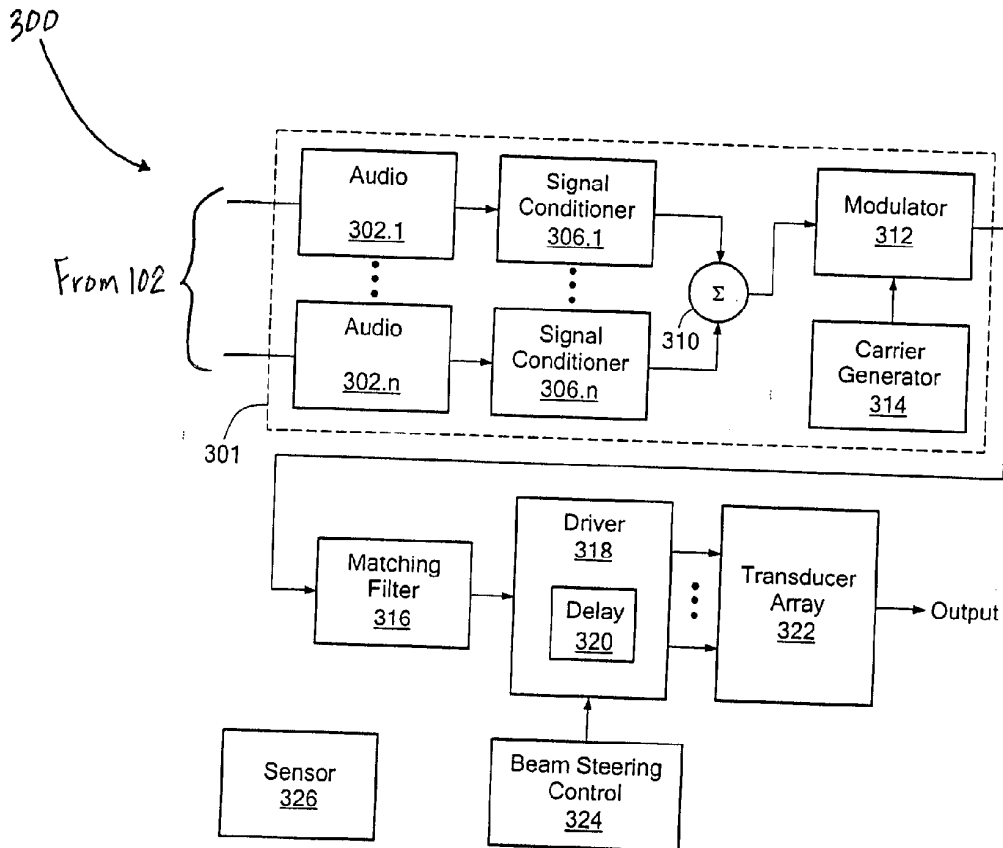

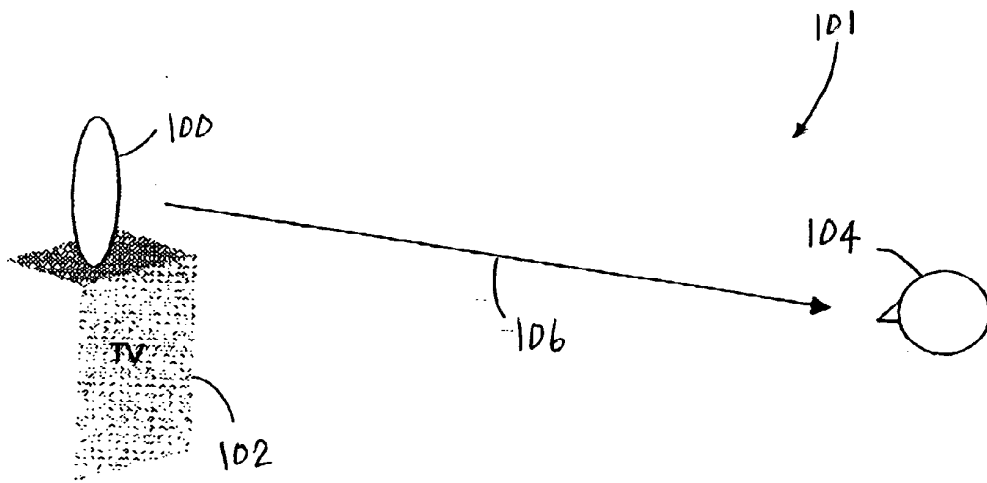

Fig. 1

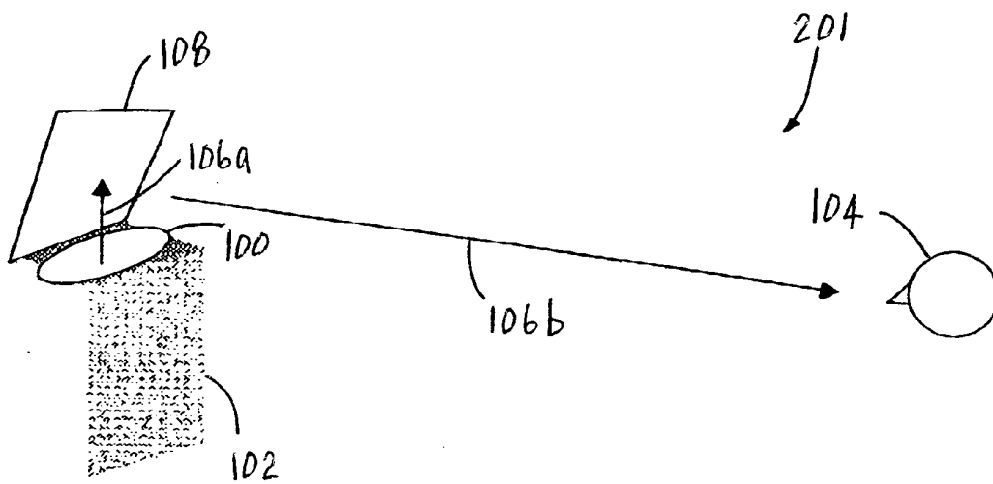

Fig. 2

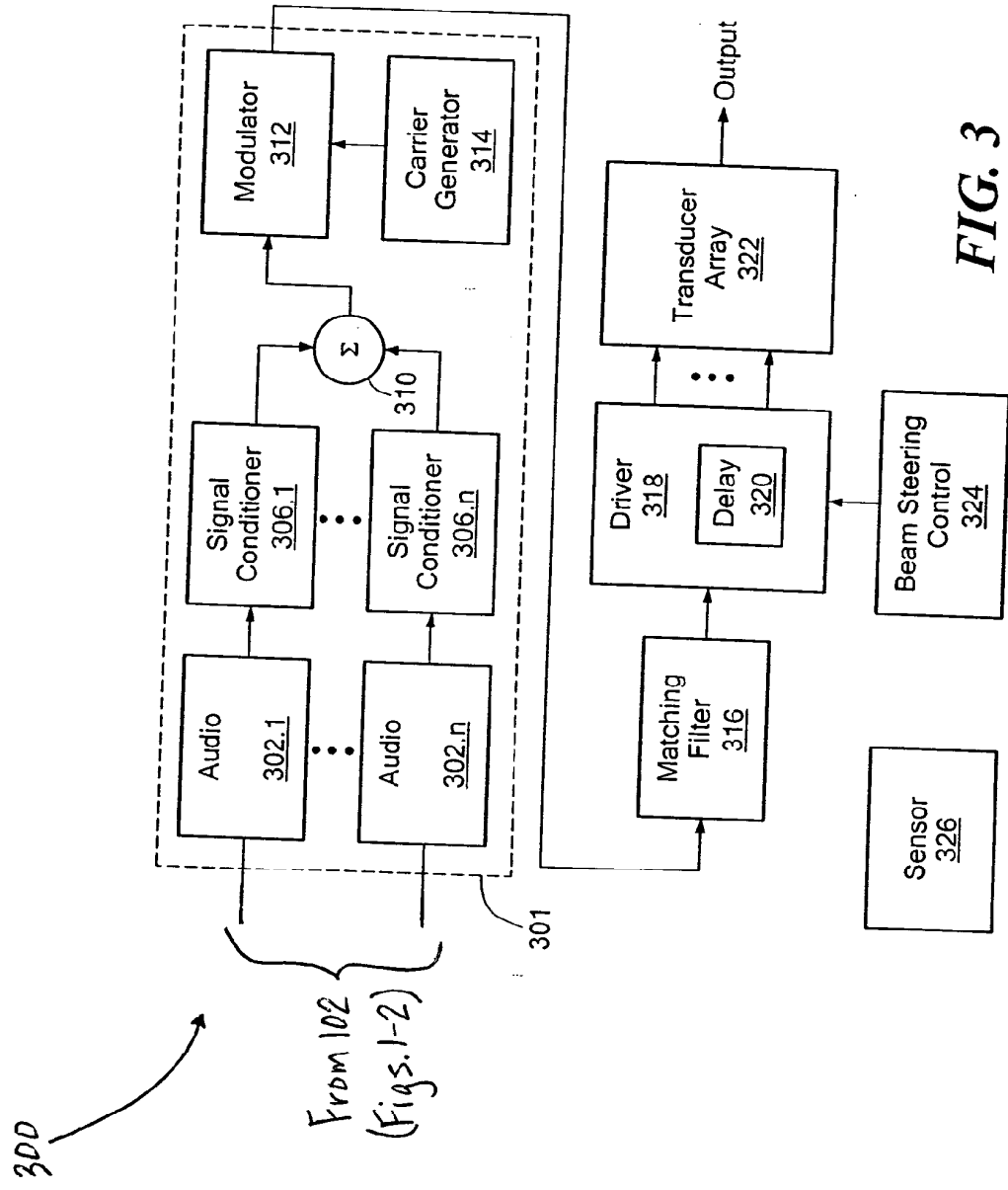
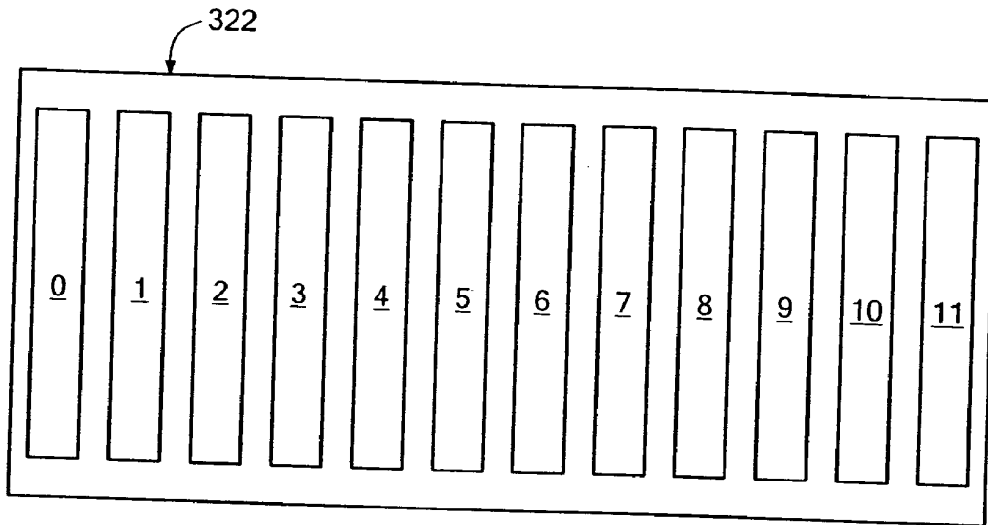
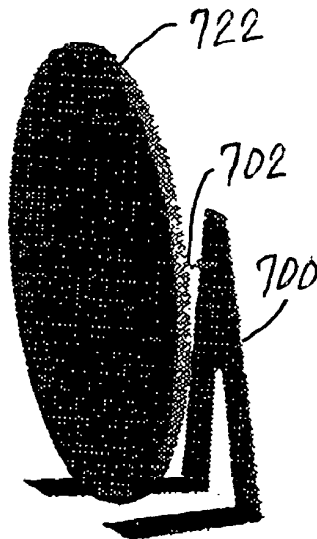

FIG. 3



**FIG. 4**



**Fig. 7**

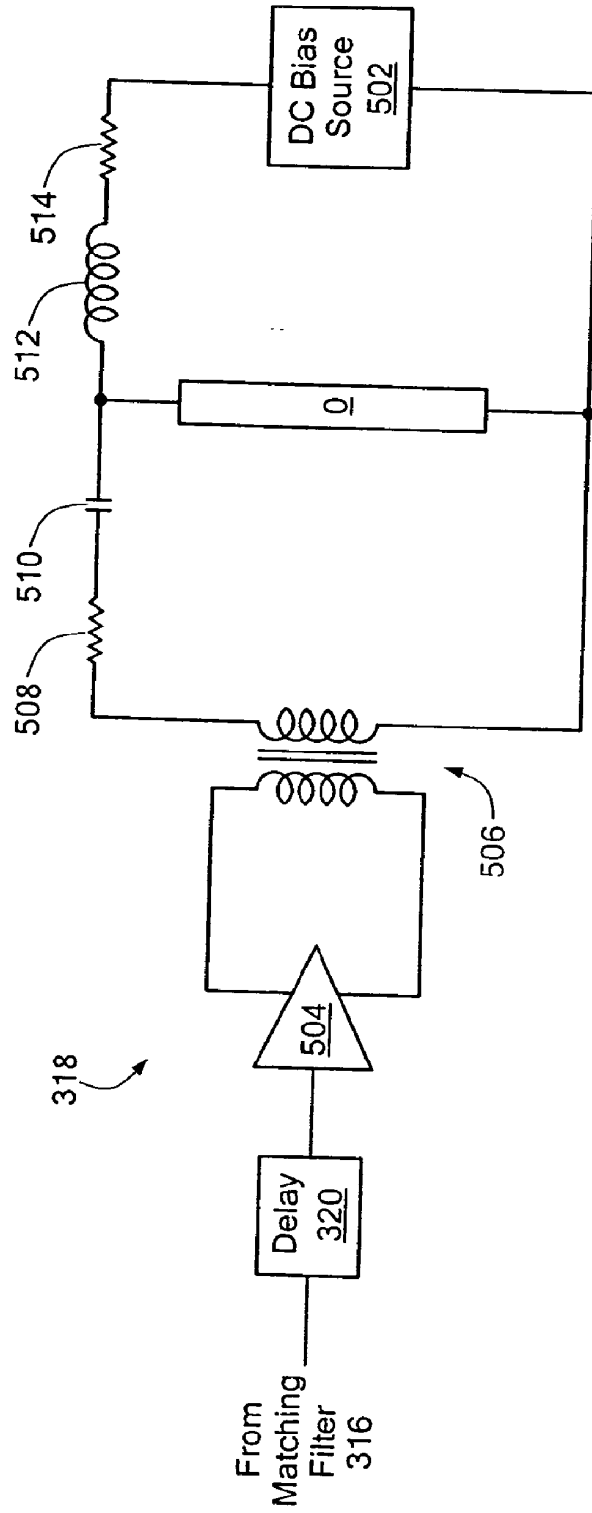

FIG. 5

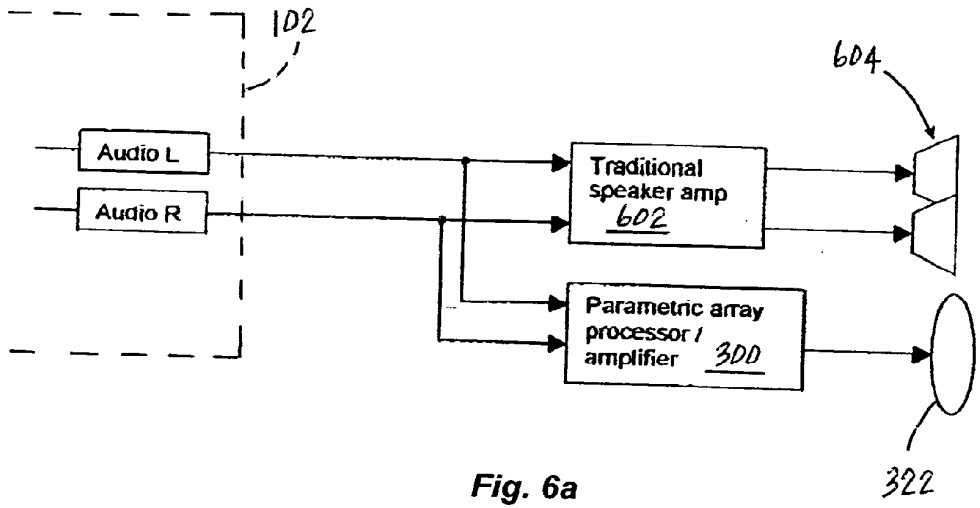

Fig. 6a

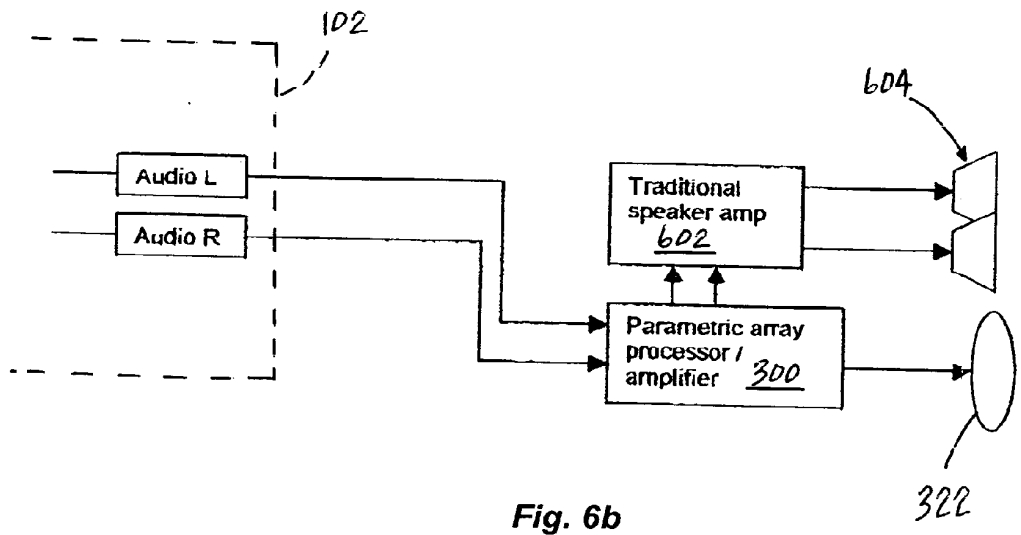

Fig. 6b

## DIRECTED ACOUSTIC SOUND SYSTEM

### CROSS REFERENCE TO RELATED APPLICATIONS

[0001] This application claims priority of U.S. Provisional Patent Application No. 60/422,582 filed Oct. 30, 2002 entitled DIRECTED ACOUSTIC SOUND SYSTEM.

### STATEMENT REGARDING FEDERALLY SPONSORED RESEARCH OR DEVELOPMENT

N/A

### BACKGROUND OF THE INVENTION

[0002] The present invention relates generally to sound systems usable in electronic entertainment systems such as televisions, radios, compact disk players, and video games, and more specifically to acoustic sound systems capable of producing highly directional sound.

[0003] In recent years, there has been a dramatic increase in the variety of electronic entertainment systems available in the marketplace. In the not-too-distant past, choices of electronic entertainment were limited primarily to radio, television, the phonograph, and the tape recorder. Today, electronic entertainment choices have expanded beyond traditional radio, television, and tape/disk recording media to include video games, compact disk players, digital video disk players, Internet radio, and MP3 systems. As a result of this dramatic increase in consumer choice, electronic entertainment systems have become ubiquitous both inside and outside the home environment.

[0004] For example, whereas families of the mid-twentieth century may have gathered around the same radio or television in their homes to enjoy favorite radio or television programs, each member of the twenty-first century household may be simultaneously engaged in a different form of electronic entertainment. Not only may such individuals enjoy chosen forms of electronic entertainment in their homes, but they may also enjoy diverse forms of electronic entertainment while walking outdoors, driving in their cars, riding on trains and airplanes, and working at their jobs, due to the reduced size and portability of today's electronic entertainment systems.

[0005] One drawback of the electronic entertainment systems available today is that the sound they generate is generally non-directional, i.e., the sound radiates essentially in all directions. Because the sound generated by such electronic entertainment systems radiates essentially omnidirectionally, virtually all people in the proximity of the system are forced to listen to the sound, including those who have no need or desire to hear it. This can lead to undue distraction at home and in the car, increased noise pollution in neighborhoods and on public transportation, and decreased efficiency in the workplace.

[0006] It would therefore be desirable to have a sound system for electronic entertainment systems and any other suitable sound-generating systems and devices that avoids the drawbacks of the above-described conventional sound systems.

### BRIEF SUMMARY OF THE INVENTION

[0007] In accordance with the present invention, an acoustic sound system usable in electronic entertainment systems

is provided that generates highly directional sound. Benefits of the presently disclosed directed acoustic sound system are achieved by employing a parametric loudspeaker that generates beams of audible sound with much higher directivity than conventional audio sound sources.

[0008] In one embodiment, the directed acoustic sound system comprises a parametric audio sound system including a modulator for modulating an ultrasonic carrier signal with a processed audio signal, a driver amplifier for amplifying the modulated carrier signal, and a parametric loudspeaker for projecting the modulated and amplified carrier signal through a propagation medium, e.g., the air, for subsequent regeneration of the audio signal along a pre-selected projection path. In a preferred embodiment, the parametric loudspeaker is a parametric array that generates sound beams using at least one membrane-type acoustic transducer. The driver amplifier may include an inductor coupled to the capacitive load of the transducer to form a resonant circuit. The center frequency of the membrane-type transducer, the resonance frequency of the resonant circuit formed by the driver amplifier coupled to the transducer, and the frequency of the ultrasonic carrier signal are equal to the same predetermined value, preferably, at least 45 kHz.

[0009] In the presently disclosed embodiment, the parametric loudspeaker operates by employing the nonlinear interaction between high frequency sound components (preferably in the ultrasonic frequency range) and the propagation medium to generate at least one beam of lower frequency sounds within the propagation medium. The result is a "virtual" sound source that is significantly larger than the wavelengths of the sounds generated by it. The larger the source of the sound, particularly in the axial direction (i.e., in the direction of propagation of the sound beam), the greater its directivity.

[0010] Accordingly, if a virtual sound source comprising a relatively long beam of ultrasound is generated using multiple frequencies, then the nonlinear interaction between the ultrasound and the propagation medium may be used to generate a narrow beam of audible sound. The directivity of the sound generated by the parametric loudspeaker can be controlled by creating a virtual sound source comprising one or more beams of ultrasound in any suitable geometric configuration, e.g., a disk, a cylinder, or a plane.

[0011] The presently disclosed directed acoustic sound system may be employed in the home, in the workplace, or in any other environment where audio leakage is undesirable. For example, the directed acoustic sound system may be used in conjunction with a television set to allow an individual to watch and to listen to the television while preventing others in the same room from hearing the sound. The directed acoustic sound system may also be used with a radio, a compact disc player, or an MP3 player to allow an individual to listen to audio selections without bothering others nearby. In addition, the directed acoustic sound system may be used with a speakerphone in an office environment to avoid distracting coworkers while enhancing the privacy of the person using the phone.

[0012] By providing electronic entertainment systems and any other suitable sound-generating systems and devices with directed acoustic sound as described above, individuals can listen to such systems without unduly distracting others in the general vicinity of the system.

[0013] Other features, functions, and aspects of the invention will be evident from the Detailed Description of the Invention that follows.

#### BRIEF DESCRIPTION OF THE SEVERAL VIEWS OF THE DRAWINGS

[0014] The invention will be more fully understood with reference to the following Detailed Description of the Invention in conjunction with the drawings of which:

[0015] FIG. 1 depicts an illustrative application of the directed acoustic sound system according to the present invention;

[0016] FIG. 2 depicts a variation of the illustrative application of the directed acoustic sound system of FIG. 1;

[0017] FIG. 3 is a block diagram of the directed acoustic sound system of FIG. 1;

[0018] FIG. 4 is a plan view of a parametric loudspeaker included in the directed acoustic sound system of FIG. 3;

[0019] FIG. 5 is a schematic diagram of a driver amplifier circuit included in the directed acoustic sound system of FIG. 3;

[0020] FIGS. 6a-6b are block diagrams of the directed acoustic sound system of FIG. 3 employed in conjunction with conventional speaker amplifiers; and

[0021] FIG. 7 is a perspective view of a directional loudspeaker included in the directed acoustic sound system of FIG. 1, the loudspeaker being mounted on a stand.

#### DETAILED DESCRIPTION OF THE INVENTION

[0022] U.S. Provisional Patent Application No. 60/422,582 filed Oct. 30, 2002 entitled DIRECTED ACOUSTIC SOUND SYSTEM is incorporated herein by reference.

[0023] A directed acoustic sound system usable in electronic entertainment systems is disclosed that is capable of generating highly directional sound. The presently disclosed directed acoustic sound system includes a parametric loudspeaker configured to generate audible sound beams with a directivity that is significantly greater than can be achieved using conventional techniques.

[0024] FIGS. 1-2 depict illustrative applications 101 and 201 of a directed acoustic sound system 100, in accordance with the present invention. As shown in FIGS. 1-2, the acoustic sound system 100 is employed in conjunction with a television set 102 for directing at least one audio sound beam 106 provided by the television to a human television viewer 104. It should be appreciated that the acoustic sound system 100 may alternatively be employed with a conventional broadcast radio, a conventional reel-to-reel or cassette tape recorder, a conventional phonograph, a Compact Disk (CD) player, a Digital Video Disk (DVD) player, a laser disk player, a video game, a desktop computer, a laptop computer, an Internet radio, an MP3 system, a speakerphone, or any other suitable electronic system or device capable of generating audible sound. FIGS. 1-2 depict the acoustic sound system 100 in conjunction with the television 102 for purposes of illustration.

[0025] As shown in FIG. 1, the directed acoustic sound system 100 includes a parametric array configured as a circular disk. The parametric array includes at least one acoustic transducer. It is noted that the parametric array may alternatively be configured as a cylinder, a plane (e.g., a rectangle), or any other suitable geometric shape. The acoustic sound system 100 is coupled to at least one audio output channel (not shown) of the television 102. Further, the acoustic sound system 100 is mounted on top of the television 102 so that the audio sound beam 106 generated by the system is directed toward the television viewer 104. Because the audio sound beam 106 generated by the acoustic sound system 100 is highly directional, the television viewer 104 can watch and listen to the television 102 without unduly distracting others nearby.

[0026] It is noted that the disk comprising the parametric array may alternatively be mounted near the television viewer 104 (e.g., on a stand located either above or to one side of the viewer 104), or directly mounted on the ceiling or a wall, so long as the audio sound beams 106 generated by the acoustic sound system 100 are substantially directed toward the viewer 104. In each case, the sound generated by the acoustic sound system 100 will only be substantially heard by listeners in the direct path of the sound beam.

[0027] For example, the parametric array and/or the reflector surface(s) may be mounted using cable hangers, picture hooks, ball mounts, or any other suitable hanging apparatus. In the preferred embodiment, ball joints are employed to allow the position of the parametric loudspeaker to be easily controlled.

[0028] As shown in FIG. 2, the directed acoustic sound system 100 is mounted on top of the television 102 so that the audio sound beam 106a generated by the system is directed upward toward a solid surface 108. Because solid surfaces generally reflect sound easily, the audio sound beam 106a is redirected by the surface 108 to direct a reflected audio sound beam 106b toward the television viewer 104. For example, the solid surface 108 may comprise a clear piece of plastic, and the disk may be permanently mounted within the housing of the television 102. Such a configuration not only provides a more aesthetically pleasing appearance, but it also allows a more thorough integration of the television electronics to facilitate fabrication of the system.

[0029] It is understood that the solid surface 108 may alternatively comprise any other suitable solid surface in a room containing the television 102. For example, any suitable wall or ceiling may be used as a sound reflector. The use of walls behind the listener may allow him or her to perceive sounds from the rear, as commonly generated by home theater systems. In this case, the listener typically remains in the direct path of the reflected audio sound beam because the sound directivity after reflection generally does not change. The home theater listening experience may be enhanced by using a number of walls to direct multiple reflected sounds toward the listener.

[0030] In the event some of the audio sound beams reaching the listener come from undesired directions (e.g., when some sound beams inadvertently reflect off of the ceiling or a wall), spatial Digital Signal Processing (DSP) filtering may be employed to eliminate the unwanted sound. Spatial DSP filtering may also be employed to create a psycho-acoustical perception of sound originating from

directions other than that actually occurring in reality. This typically involves subtle filtering and delaying of audio signals before directing the sound to the listener. It is understood that two or more audio sound beams generated using any of the above-described configurations may be employed for stereo listening.

[0031] FIG. 3 depicts an illustrative embodiment 300 of the directed acoustic sound system 100 (see FIG. 1). In the illustrated embodiment, the directed acoustic sound system 300 comprises a parametric audio sound system including a signal generator 301, an optional matching filter 316, a driver amplifier 318 coupleable to optional beam steering control circuitry 324, and a parametric array 322, which comprises one or more acoustic transducers. A parametric audio system like that included in the directed acoustic sound system 300 is disclosed in co-pending U.S. patent application Ser. No. 09/758,606 filed Jan. 11, 2001 entitled PARAMETRIC AUDIO SYSTEM, which is incorporated herein by reference.

[0032] Specifically, the parametric array 322 includes at least one acoustic transducer configured to be driven by the signal generator 301, which includes a modulator 312 coupled to an ultrasonic carrier signal generator 314, and one or more audio channels 302.1-302.n. For example, the television 102 (see FIGS. 1-2) may provide one or more audio signals (e.g., audio Left (L) and audio Right (R); see also FIGS. 6a-6b) to the audio channels 302.1-302.n. Optional signal conditioning circuits 306.1-306.n receive respective audio signals provided via the audio channels 302.1-302.n, and provide conditioned audio signals to a summer 310. It is noted that such conditioning of the audio signals may alternatively be performed after the audio signals are summed by the summer 310. The modulator 112 receives a composite audio signal from the summer 310 and an ultrasonic carrier signal from the carrier generator 314, and modulates the ultrasonic carrier signal with the composite audio signal. The modulator 312 is preferably adjustable in order to vary the modulation index. Amplitude modulation by multiplication with a carrier is preferred, but because the ultimate goal of such modulation is to convert audio-band signals into ultrasound, any form of modulation providing that result may be used. The modulator 312 provides the modulated carrier signal to the optional matching filter 316, which is configured to compensate for the generally non-flat frequency response of the driver amplifier 318 and the parametric array 322. The matching filter 316 provides the modulated carrier signal to the driver amplifier 318, which in turn provides an amplified version of the modulated carrier signal to the acoustic transducer of the parametric array 322. The driver amplifier 318 may include a delay circuit 320 configured to apply a relative phase shift and/or amplitude shading across multiple frequencies of the modulated carrier signal to steer, focus, or shape the ultrasonic beam generated at the output of the parametric array 322. The ultrasonic beam, which comprises the high intensity ultrasonic carrier signal amplitude-modulated with the composite audio signal, is demodulated on passage through the propagation medium, e.g., the air, due to the air's non-linear propagation characteristics, thereby generating audible sound.

[0033] In the preferred embodiment, the frequency of the carrier signal generated by the ultrasonic carrier signal generator 314 is on the order of 45 kHz or higher. Because

the audio signals provided via the audio channels 302.1-302.n typically have a maximum frequency of about 20 kHz, the lowest frequency components of substantial intensity according to the strength of the audio signal in the modulated ultrasonic carrier signal have a frequency of about 25-35 kHz or higher. Such frequencies are typically above the range of human hearing.

[0034] FIG. 4 depicts an illustrative embodiment of the parametric array 322 included in the directed acoustic sound system 300 (see FIG. 3). In the illustrated embodiment, the parametric array 322 includes a plurality of acoustic transducers 0-11 arranged in a one-dimensional configuration. It should be understood, however, that the plurality of acoustic transducers may alternatively be arranged in 2-3 dimensional configurations. Each of the acoustic transducers 0-11 has a generally rectangular shape to facilitate close packing in the one-dimensional configuration. It should be understood, however, that other suitable geometrical shapes (e.g., a disk or a cylinder) and other suitable configurations of the acoustic transducers may be employed. For example, the acoustic transducers may be shaped for arrangement in an annular or "ring" configuration.

[0035] In the preferred embodiment, each of the acoustic transducers 0-11 comprises a capacitor transducer, more particularly a membrane-type transducer such as a membrane-type PVDF transducer, a membrane-type electret transducer, a membrane-type electrostrictive transducer, or a membrane-type electrostatic transducer (e.g., a Sell-type electrostatic transducer). In an alternative embodiment, the acoustic transducers 0-11 may comprise piezoelectric transducers. It is noted that the bandwidth of the parametric array 322 is preferably on the order of 5 kHz or higher, and more preferably on the order of 10 kHz or higher as enhanced by the matching filter 316. Membrane-type transducers suitable for use in the acoustic sound system 300 are described in copending U.S. patent application Ser. No. 09/300,200 filed Apr. 27, 1999 entitled ULTRASONIC TRANSDUCERS, and copending U.S. patent application Ser. No. 10/268,004 filed Oct. 9, 2002 entitled ULTRASONIC TRANSDUCER FOR PARAMETRIC ARRAY, which are incorporated herein by reference.

[0036] FIG. 5 depicts an illustrative embodiment of the driver amplifier 318 included in the directed acoustic sound system 300 (see FIG. 3). In the illustrated embodiment, the driver amplifier 318 includes the delay circuit 320, an amplifier 504, a transformer 506, resistors 508 and 514, a capacitor 510, an inductor 512, the acoustic transducer 0, and a DC bias source 502. It is noted that a respective delay circuit 320 is preferably provided for each of the acoustic transducers 0-11 (see FIG. 4). FIG. 5 shows the driver amplifier 318 driving only the acoustic transducer 0 for clarity of discussion.

[0037] As shown in FIG. 5, the delay circuit 320 receives the modulated carrier signal from the matching filter 316 (see FIG. 3), applies a relative phase shift and/or amplitude shading to the modulated carrier signal for steering/focusing/shaping the ultrasonic beam generated by the parametric array 322, and provides the modulated carrier signal to the amplifier 504. The primary winding of the transformer 506 receives the output of the amplifier 504, and the secondary winding of the transformer 506 provides a stepped-up voltage to the series combination of the acoustic transducer 0,

the resistor **508**, and the blocking capacitor **510**. Further, a DC bias is applied to the acoustic transducer **0** from the DC bias source **502** via the isolating inductor **512** and the resistor **514**. The capacitor **510** has relatively low impedance and the inductor **512** has relatively high impedance at the operating frequency of the driver amplifier **318**. Accordingly, these components typically have minimal effect on the circuit operation except to isolate the AC and DC portions of the circuit. In an alternative embodiment, the inductor **512** may be replaced by a very large resistor value. It is noted that the blocking capacitor **510** may be omitted when the DC bias is provided by an electret.

[**0038**] In a preferred embodiment, the secondary winding of the transformer **506** is configured to resonate with the capacitance of the acoustic transducer **0** at the center frequency of the acoustic transducer **0**, e.g., 45 kHz or higher. This effectively steps-up the voltage across the acoustic transducer and provides a highly efficient coupling of the power from the driver amplifier **318** to the acoustic transducer. Without the resonant circuit formed by the secondary winding of the transformer **506** and the acoustic transducer capacitance, the power required to drive the acoustic sound system **300** would be very high, i.e., on the order of hundreds of watts. With the resonant circuit, the power requirement reduction corresponds to the Q-factor of resonance. It is noted that the electrical resonance frequency of the driver amplifier **318**, the center frequency of the acoustic transducer **0**, and the ultrasonic carrier frequency preferably have the same frequency value.

[**0039**] As described above, the delay circuit **320** (see FIGS. **3** and **5**) applies a relative phase shift and/or amplitude shading across multiple frequencies of the modulated carrier signal to steer, focus, or shape ultrasonic beams generated by the parametric array **322**. The parametric array **322**, more particularly the one-dimensional parametric array **322** of FIG. **4**, is therefore well suited for use as a phased array. Such phased arrays may be employed for electronically steering audio beams toward desired locations along selected projection paths, without requiring mechanical motion of the parametric array **322**. Further, such phased arrays may be used to vary audio beam characteristics such as the beam width, the beam focus, and the beam spread.

[**0040**] Specifically, the parametric array **322** operates as a phased array by manipulating the phase relationships between the acoustic transducers included therein to obtain a desired interference pattern in the ultrasonic field. For example, the one-dimensional parametric array **322** (see FIG. **4**) may manipulate the phase relationships between the acoustic transducers **0-11** via the delay circuit **320** (see FIGS. **3** and **5**) so that constructive interference of ultrasonic beams occurs in one desired direction. As a result, the one-dimensional parametric array **322** steers the modulated ultrasonic beam in that direction electronically. Further, the direction of the modulated ultrasonic beam may be changed in real-time via the beam steering control circuitry **324** (see FIG. **3**).

[**0041**] FIGS. **6a-6b** depict the directed acoustic sound system **300** employed in conjunction with conventional speaker amplifiers. In the preferred embodiment, the signal handling capability of the acoustic sound system **300** accommodates the use of conventional loudspeakers **604** and/or the

directional acoustic transducer loudspeaker **322**, depending on the needs of the listener and the characteristics of the listening environment.

[**0042**] As shown in FIG. **6a**, the television **102** (see FIGS. **1-2**) provides audio L and audio R signals to a conventional speaker amplifier **602** and to the parametric array processor/amplifier of the directed acoustic sound system **300**. For example, the speaker amplifier **602** may comprise a class AB audio speaker amplifier, a class D audio speaker amplifier, or any other suitable audio speaker amplifier for driving the conventional loudspeakers **604**. In the illustrated embodiment, the speaker amplifier **602** and the acoustic sound system **300** are connected in parallel. It is noted that the acoustic sound system **300** may include a stereo parametric array amplifier, or a mono parametric array amplifier requiring a combination of the audio L and audio R channels. In the configuration of FIG. **6a**, the conventional speaker system including the loudspeakers **604** may be muted or turned-off when it is desired to hear only the acoustic sound system including the directional loudspeaker **322**. Similarly, the acoustic sound system including the directional loudspeaker **322** may be muted or turned-off when it is desired to hear only the conventional speaker system including the loudspeakers **604**.

[**0043**] As shown in FIG. **6b**, the television **102** (see FIGS. **1-2**) provides the audio L and audio R signals to the parametric array processor/amplifier of the directed acoustic sound system **300**. In the illustrated embodiment, the speaker amplifier **602** and the acoustic sound system **300** are connected in series, i.e., the directed acoustic sound system is connected in-line with the conventional speaker system. In this configuration, the listener may select the conventional speaker system, the directed acoustic sound system, or both systems, by simply making a selection using known mechanical and/or electronic techniques. In the event the listener selects the directional loudspeaker **322** only, the audio L and audio R signals are combined and subsequently recreated by the directed acoustic sound system **300**, and the corresponding audio L and R signals normally provided to the conventional speaker amplifier **602** are made to be approximately zero. In the event the listener desires a more traditional listening experience, the audio L and R signals are provided to the speaker amplifier **602** while the signal processing circuitry of the acoustic sound system **300** is placed in an inactive state.

[**0044**] As shown in FIGS. **6a-6b**, the audio L and audio R signals are provided by the television **102** (see FIGS. **1-2**). Such televisions typically have at least one line-out connector for audio output signals. It is noted that the listener may be required to mute the internal loudspeaker of the television when using the line-out connection. In alternative embodiments, the audio output signals may be provided by an auxiliary signal source such as a Video Cassette Recorder (VCR), a cable TV box, a DVD player, or any other suitable signal source. The television **102** may also have a headphone jack (not shown), which may be used to capture audio output signals for subsequent reproduction by the directional loudspeaker **322**. Moreover, audio signals may be provided by multiple electronic systems, e.g., a television, a CD player, and a speakerphone. In this case, the listener may first select the desired system, and then select the conventional speaker system or the directional speaker system for reproducing the audio signals provided by that system.

be mounted from a fixture attached to a cubicle by a "swing-arm" assembly like those typically used with desk lamps. This allows the audio sound beams to be aimed directly at the intended listener. Moreover, because it requires virtually no user adjustments, the acoustic sound system may be placed in any convenient location. Audio output signals from the hands-free telephone system (and/or the personal computer) may be provided to the conveniently located acoustic sound system to power the directional speaker.

[0055] It will also be appreciated by those of ordinary skill in the art that further modifications to and variations of the above-described directed acoustic sound system may be made without departing from the inventive concepts disclosed herein. Accordingly, the invention should not be viewed as limited except as by the scope and spirit of the appended claims.

What is claimed is:

1. A system for reproducing audio signals, comprising:
  - at least one source of audio signals, the audio signals corresponding to at least one audio channel;
  - a modulated signal generator configured to generate an ultrasonic carrier signal modulated with at least one of the audio signals;
  - a driver amplifier configured to amplify the modulated ultrasonic carrier signal; and
  - at least one directional loudspeaker, the directional loudspeaker including at least one acoustic transducer configured to receive the modulated ultrasonic carrier signal amplified by the driver amplifier, and to project a sound beam representing the modulated ultrasonic carrier signal through a propagation medium along a pre-selected path to reproduce the at least one audio signal along at least a portion of the path.
2. The system of claim 1 wherein the audio signals correspond to a plurality of audio channels, wherein the at least one directional loudspeaker comprises a plurality of directional loudspeakers, and wherein a separate audio channel is provided for each directional loudspeaker.
3. The system of claim 1 wherein the audio signals correspond to a plurality of audio channels, and wherein the modulated signal generator is configured to combine the plurality of audio channels and to generate the ultrasonic carrier signal modulated with the combined audio channels.
4. The system of claim 1 wherein the audio signals correspond to a plurality of audio channels, the plurality of audio channels being selected from the group consisting of a first audio channel corresponding to a first location in front of a user of the system, a second audio channel corresponding to a second location in back of the system user, a third audio channel corresponding to a third location to the left of the system user, and a fourth audio channel corresponding to a fourth location to the right of the system user.
5. The system of claim 1 further including at least one sensor configured to detect a distance from the directional loudspeaker to a user of the system or to detect a position of the user relative to the system.
6. The system of claim 5 wherein the modulated signal generator is configured to generate an ultrasonic signal having characteristics based at least in part on the detected distance to the system user or the detected position of the system user.
7. The system of claim 5 wherein the sensor comprises a device selected from the group consisting of an optical ranging device, an acoustic ranging device, and an infrared ranging device.
8. The system of claim 1 wherein the acoustic transducer is selected from the group consisting of a piezoelectric transducer, an electrostatic transducer, a PVDF film transducer, and an electrostrictive film transducer.
9. The system of claim 1 further including a delay circuit configured to apply a relative phase shift across a plurality of frequencies of the modulated ultrasonic carrier signal to steer, focus, or shape the sound beam projected by the directional loudspeaker.
10. The system of claim 1 wherein the system is selected from the group consisting of a television, a radio, an audio tape player, a phonograph, a compact disk player, a digital video disk player, a laser disk player, a video game, a desktop computer, a laptop computer, and an MP3 system.
11. The system of claim 1 further including a second amplifier and at least one non-directional loudspeaker, the second amplifier being configured to amplify one or more audio signals corresponding to at least one of the audio channels and to drive at least one non-directional loudspeaker.
12. The system of claim 11 wherein the modulated signal generator and the second amplifier are configured to receive the at least one audio channel in parallel.
13. The system of claim 11 wherein the modulated signal generator is configured to receive the at least one audio channel and to provide a representation of the at least one audio channel to the second amplifier.
14. The system of claim 11 wherein the modulated signal generator is configured to selectively generate the ultrasonic carrier signal modulated with the at least one of the audio signals, and the second amplifier is configured to selectively amplify the one or more audio signals, thereby allowing only the directional loudspeaker, only the non-directional loudspeaker, or both the directional loudspeaker and the non-directional loudspeaker, to reproduce the audio signals.
15. The system of claim 1 wherein the modulated signal generator includes an independent volume control.
16. The system of claim 1 further including a remote signal receiver and a remote control device configured to generate remote signals in response to a user input, wherein the remote signal receiver is configured to receive the remote signals and generate control signals for controlling a system characteristic selected from the group consisting of a volume setting, a tone setting, and an output switch selection.
17. The system of claim 16 wherein the remote control device is selected from the group consisting of an optical remote control device, an acoustic remote control device, an infrared remote control device, and a radio frequency remote control device.
18. The system of claim 1 further including a fan configured to cool the system.
19. The system of claim 18 wherein the fan is activated automatically when a system temperature exceeds a predetermined level.